

Circuit Diagram of Power Supply

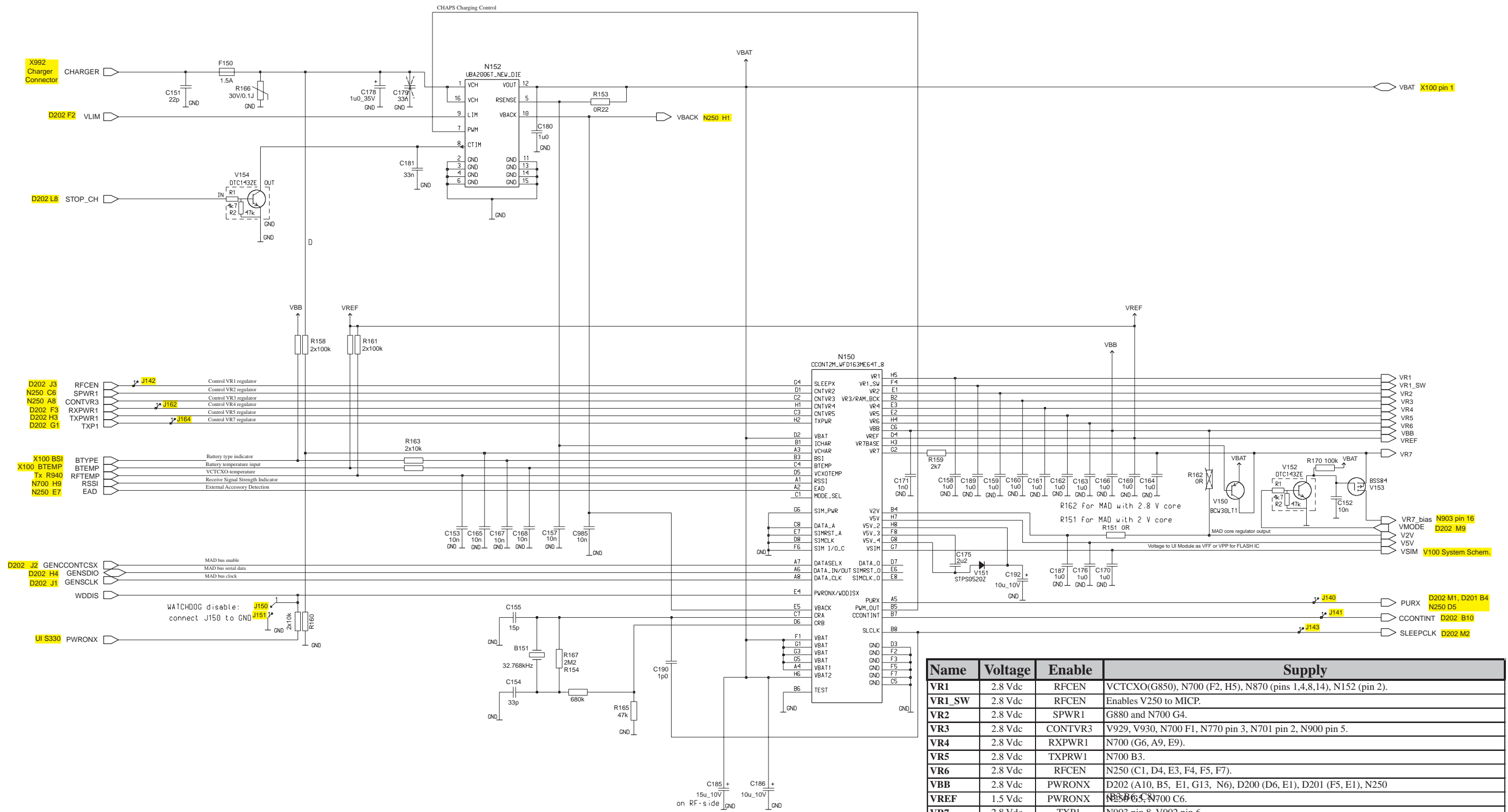

Circuit Diagram of RX

Name	Voltage	Enable	Supply
VR8	2.8 Vdc	RXPWR2	N701 pins 5 and 16.
VR9	2.8 Vdc	RXPWR3	N721 pins 5, 14 and 16.
VR10	2.8 Vdc	SPWR3	G881, N870 pin 9, N721 pin 2.
VR11	2.8 Vdc	TXP2	N960 pin 8, N951 pins 4 and 6.
VR12	2.8 Vdc	TXPWR2	N980 pins 1,8,12,16

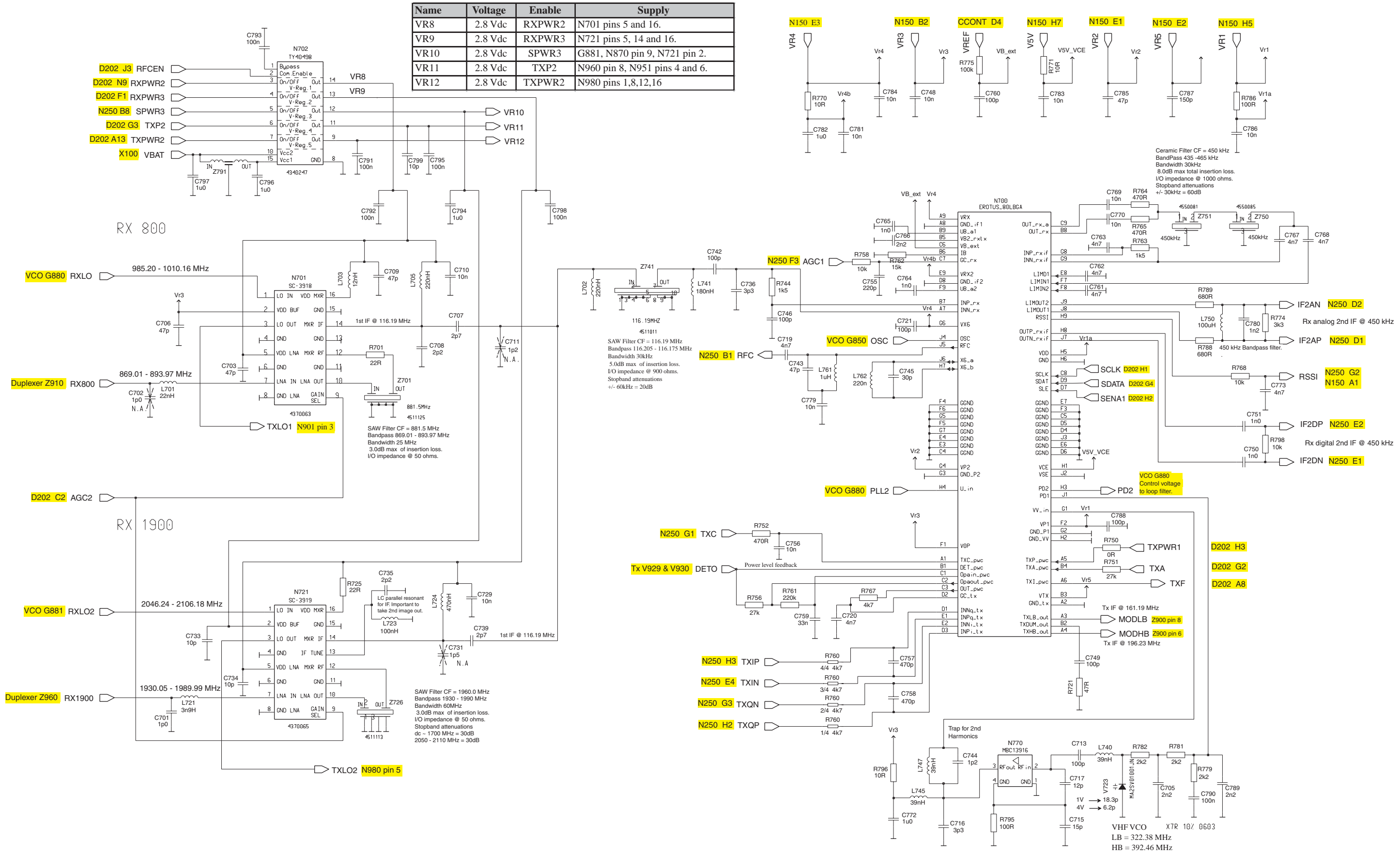

Circuit Diagram of TX

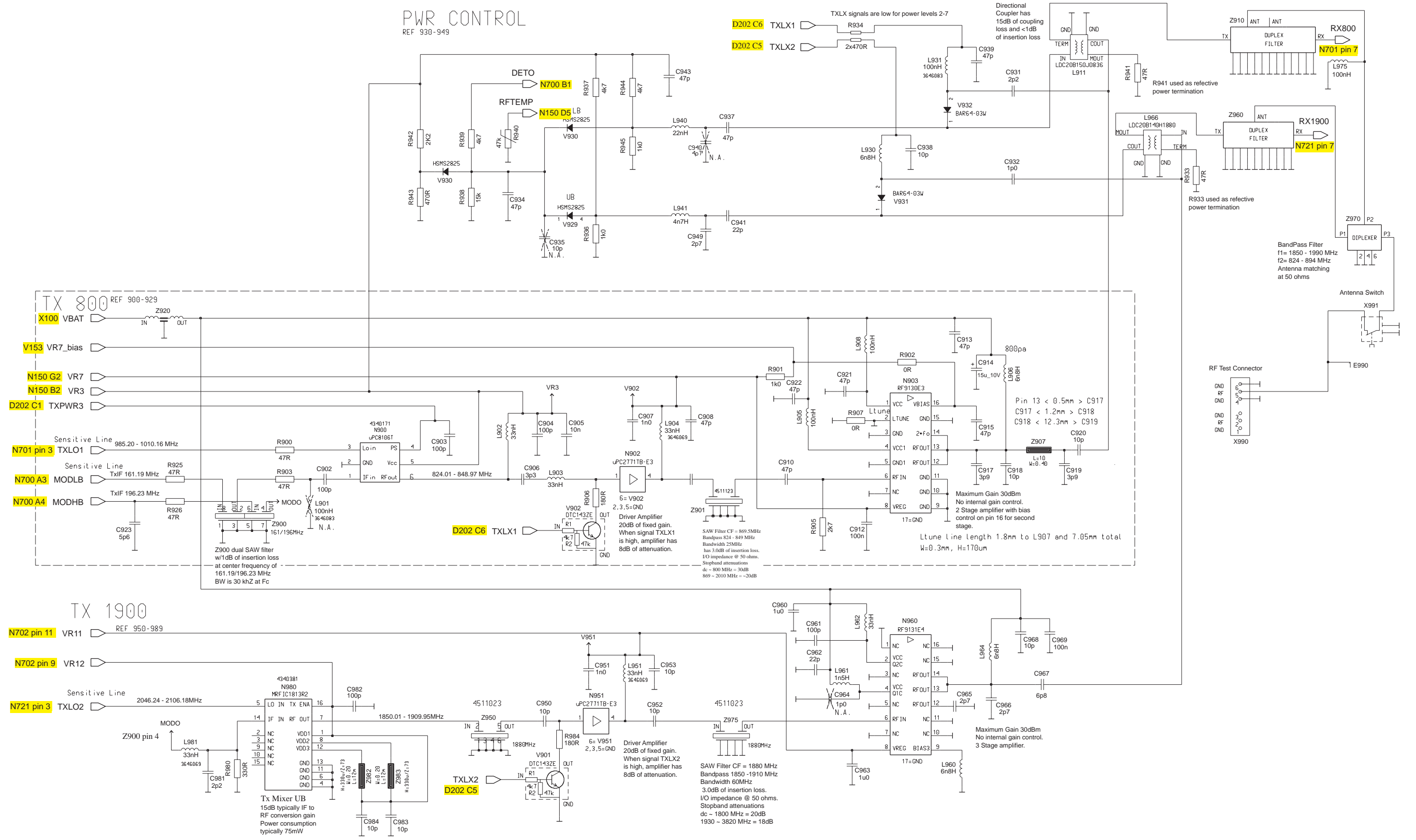

Circuit Diagram of Synthesizer

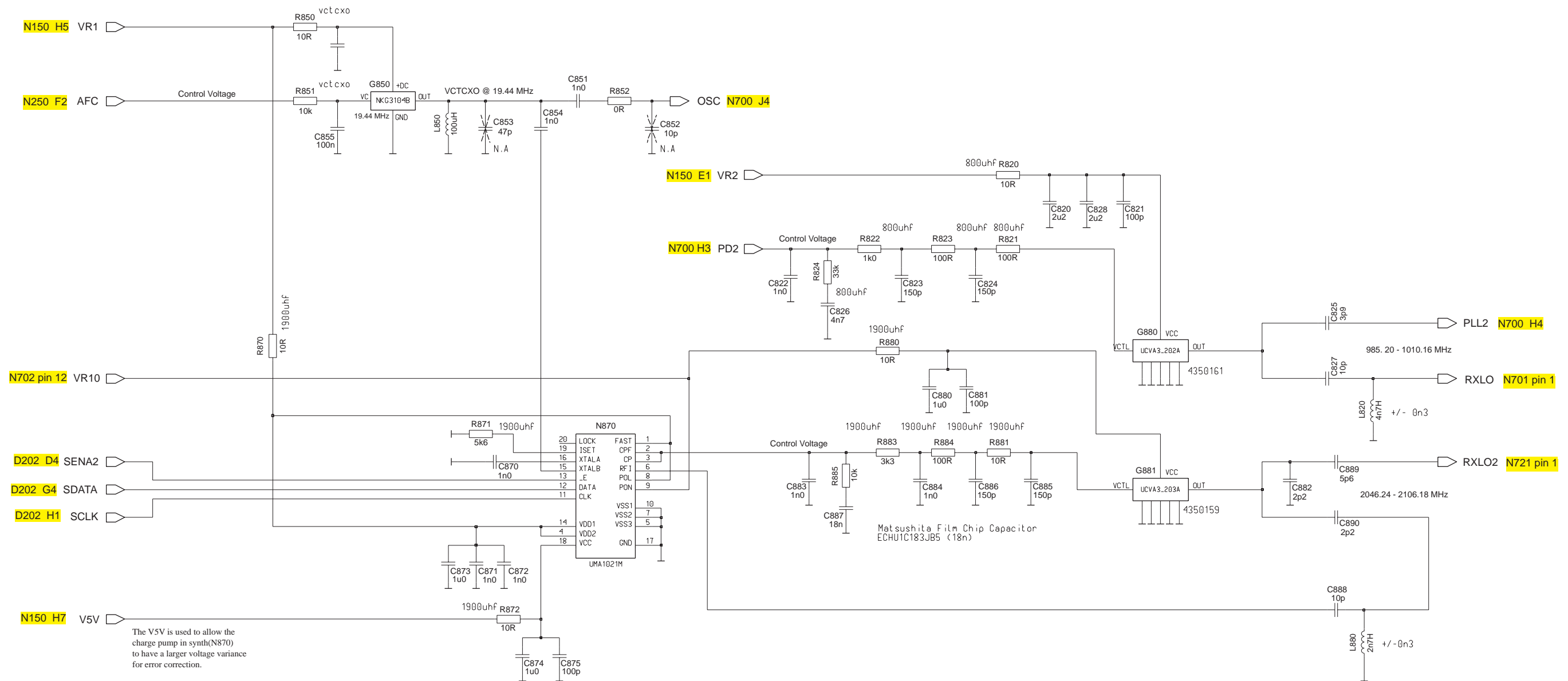

Circuit Diagram of Audio

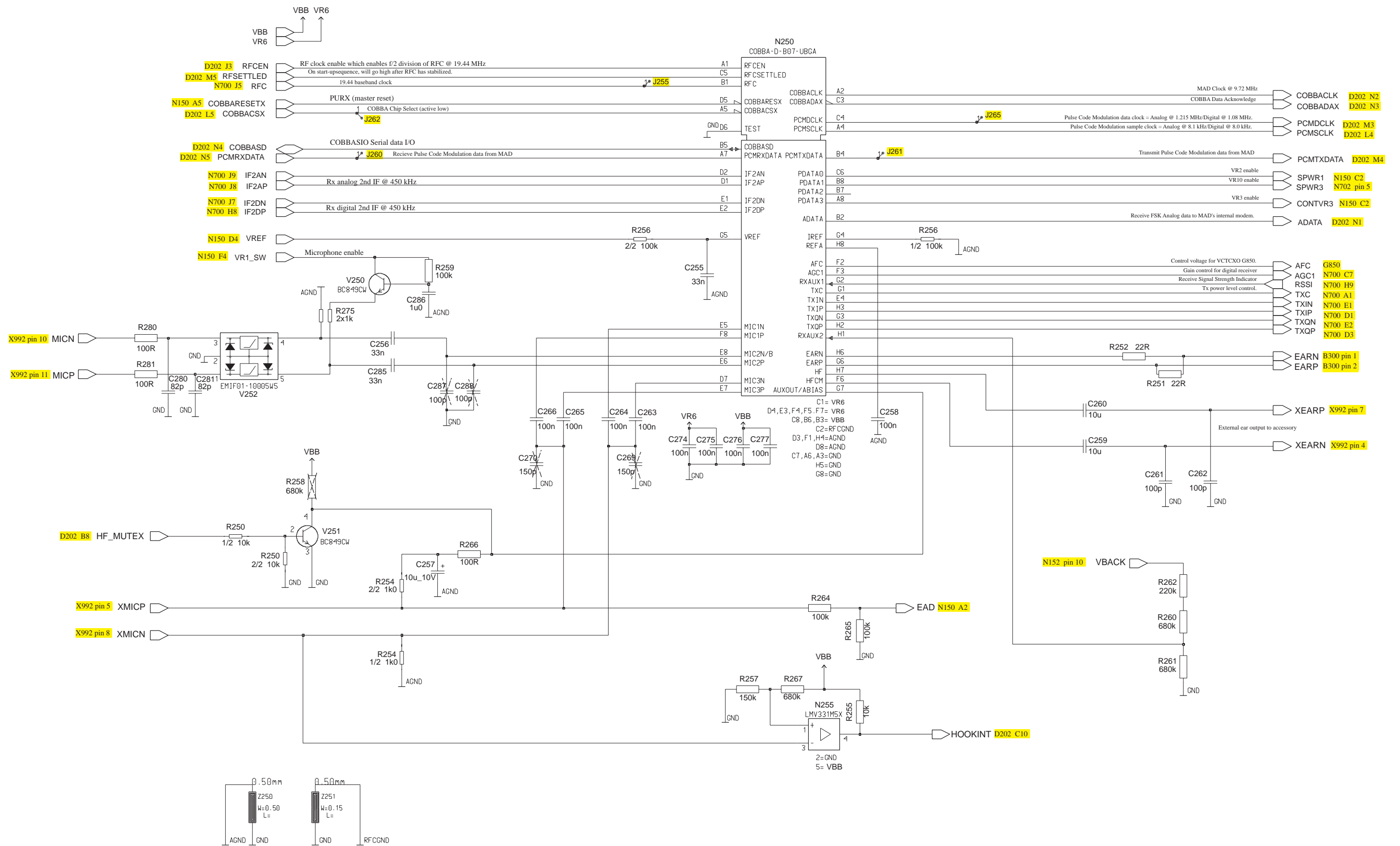

Circuit Diagram of Control Memory

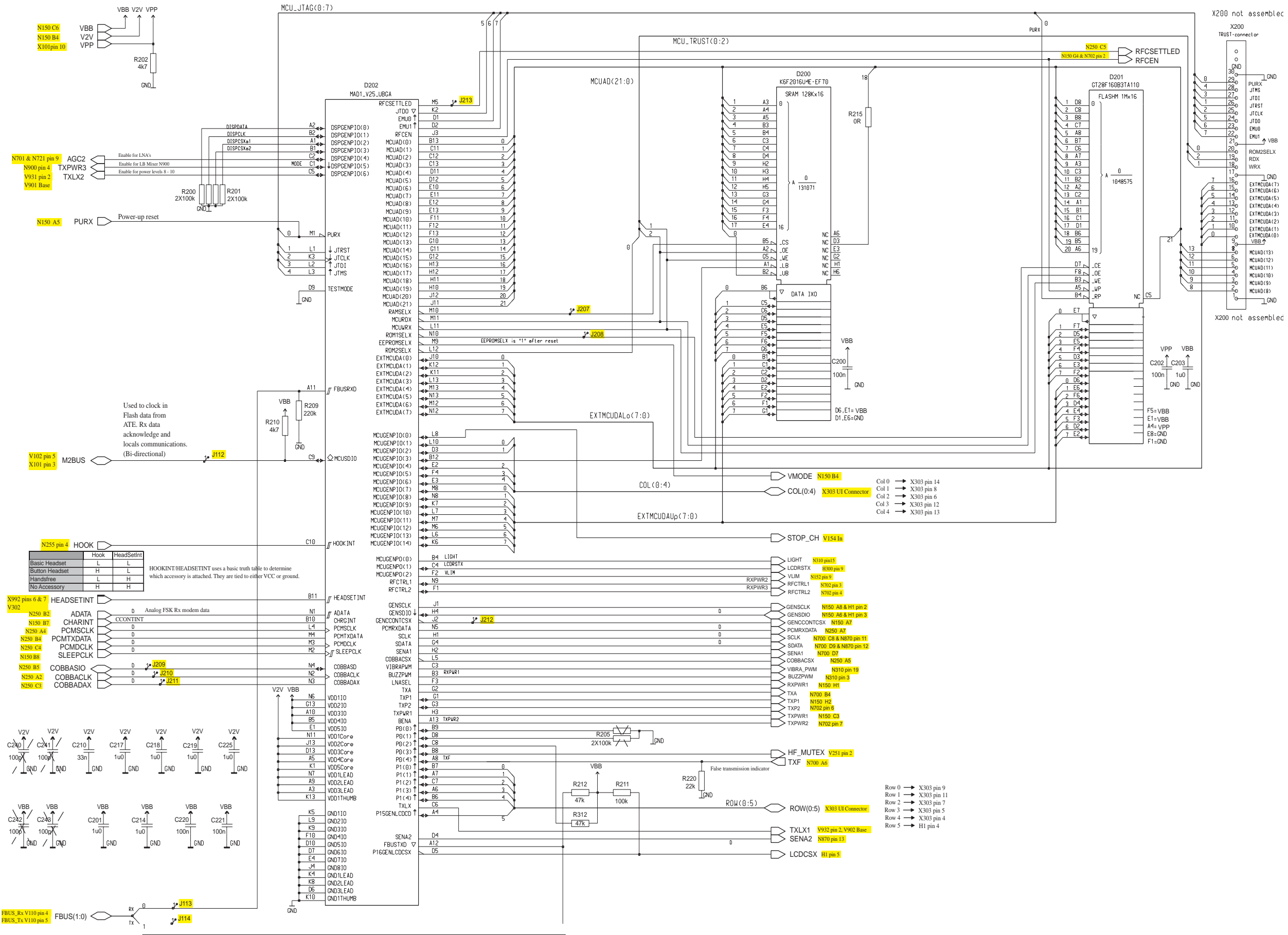

Circuit Diagram of System

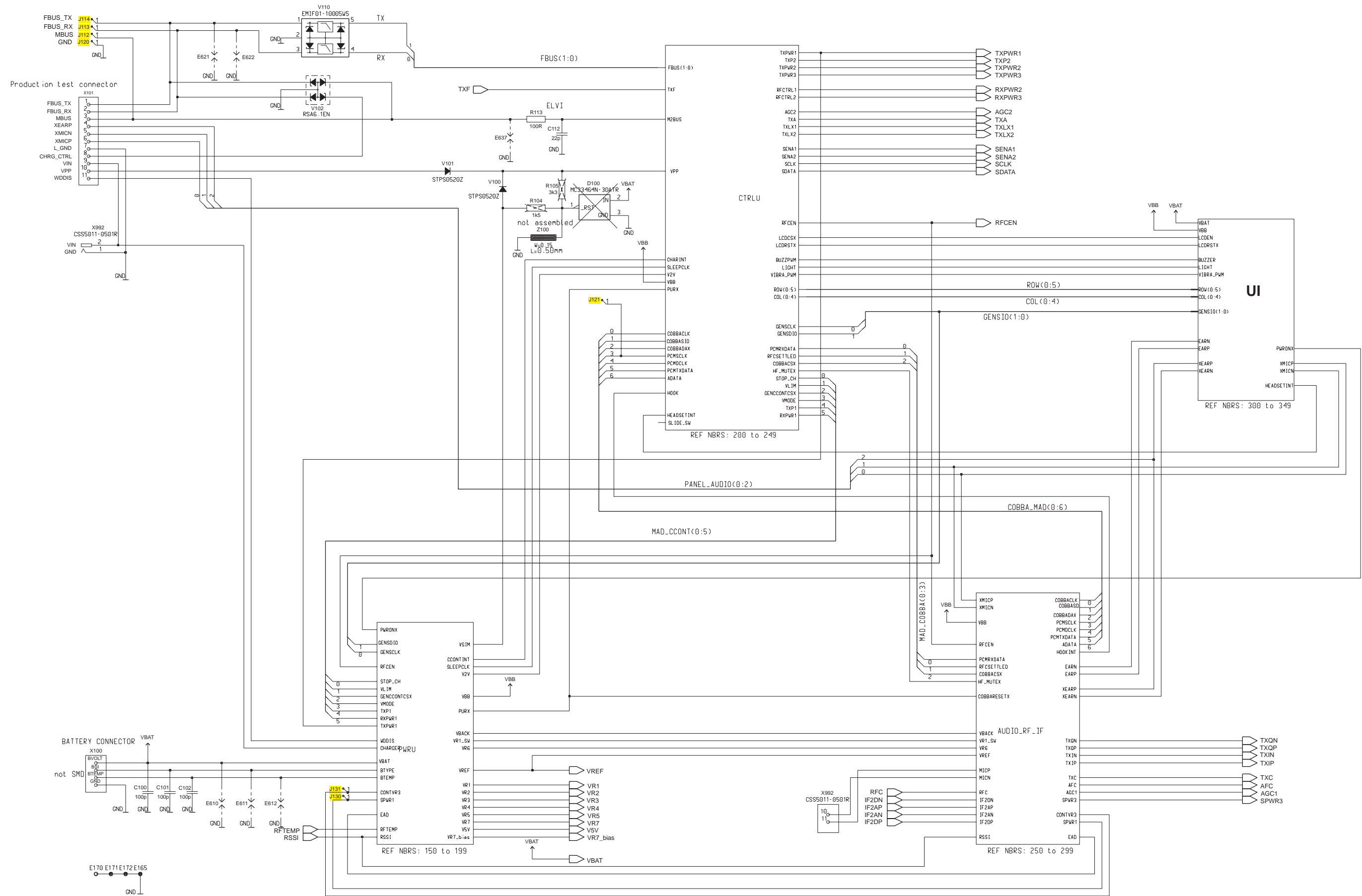

Circuit Diagram of UI

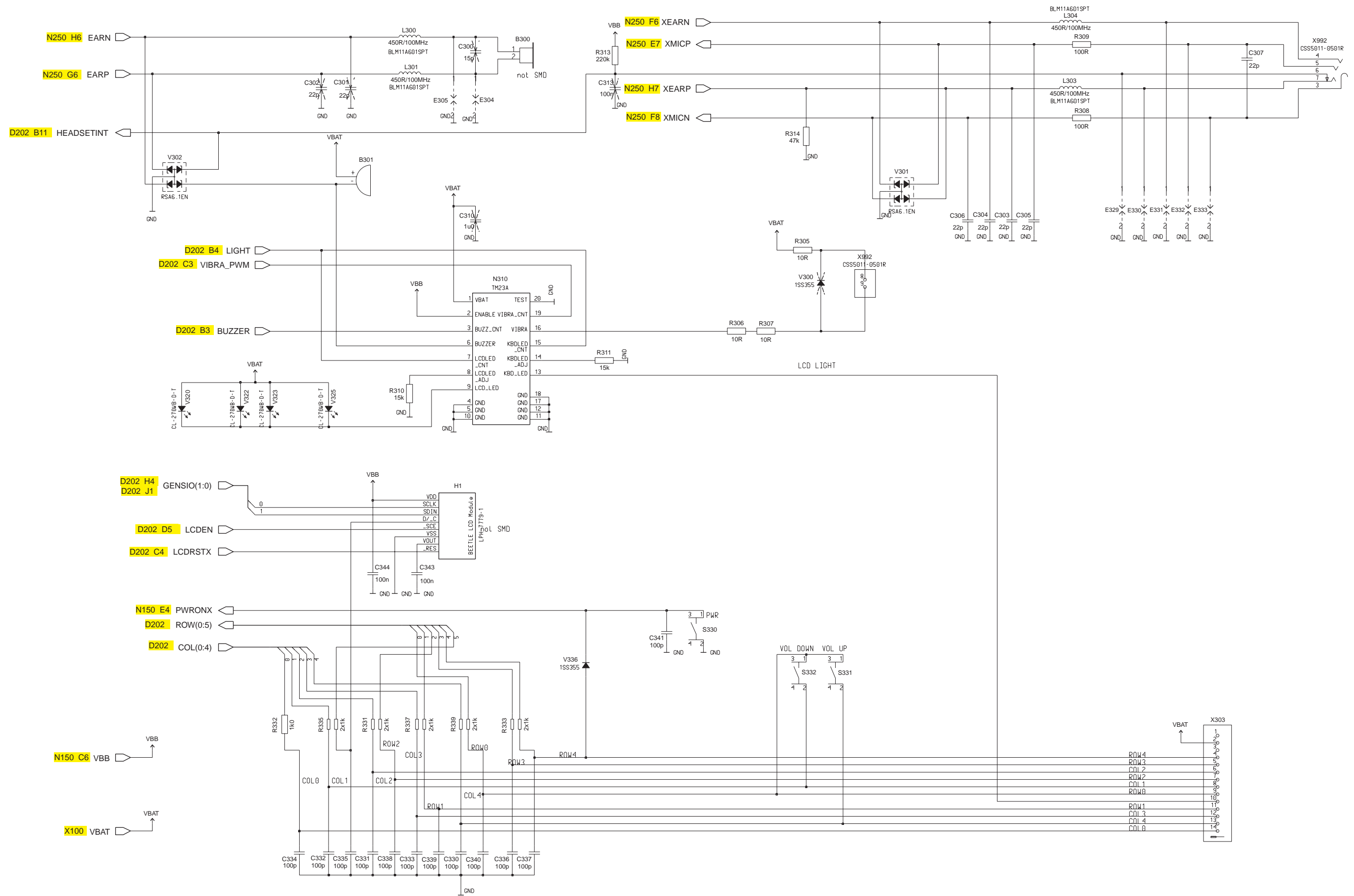



Block Diagram

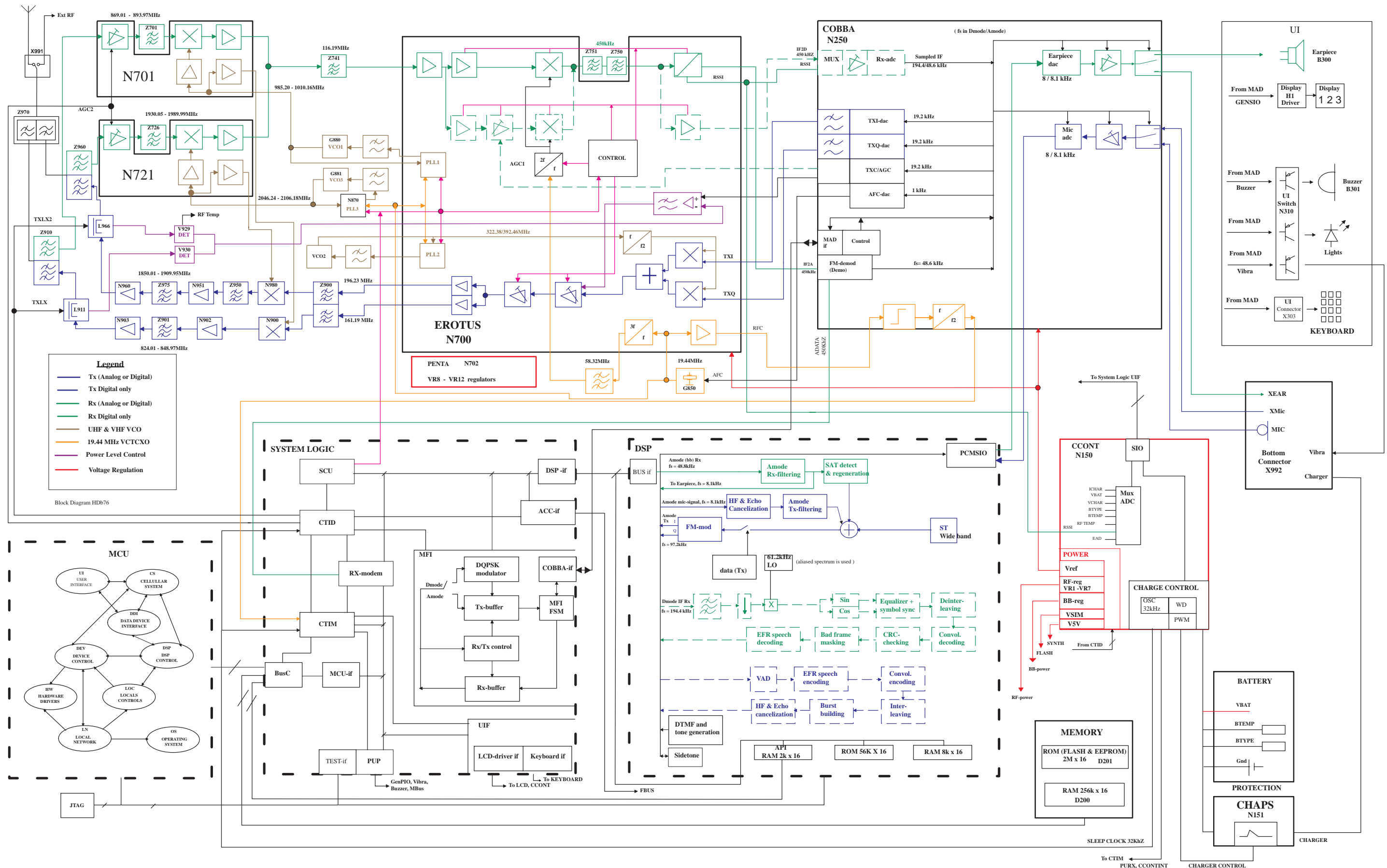

Component Diagram - Top

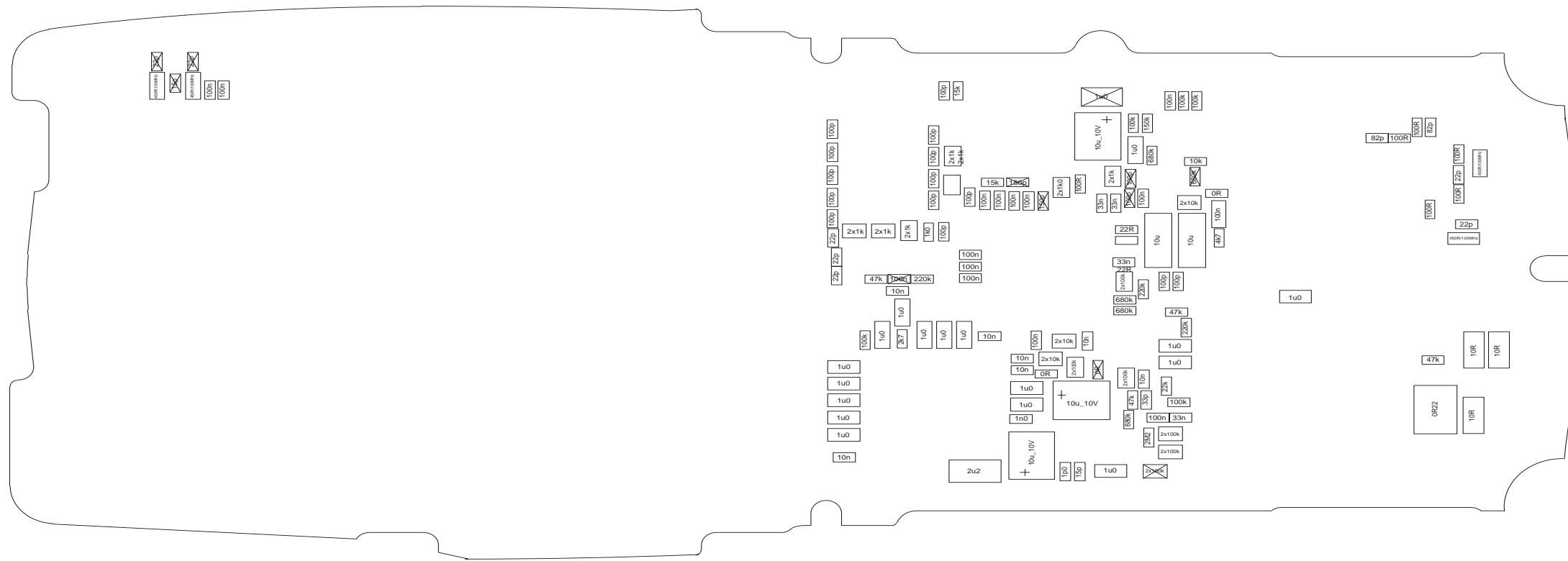

Component Layout - Top

